



US 20050226740A1

(19) **United States**

(12) **Patent Application Publication** (10) **Pub. No.: US 2005/0226740 A1**

Bhatia et al.

(43) **Pub. Date: Oct. 13, 2005**

(54) **COMPRESSOR HAVING REAR HOUSING STRUCTURE TO REDUCE THE OPERATING TEMPERATURE**

Publication Classification

(51) **Int. Cl.⁷ F04B 17/00; F04B 35/00**

(52) **U.S. Cl. 417/373; 417/423.8; 417/423.14; 417/572**

(75) **Inventors: Kanwal G. Bhatia, Troy, MI (US); Eric Bryan Gheen, Dearborn, MI (US); Vipen Khetarpal, Novi, MI (US); Aurelian Bahmata, Novi, MI (US)**

(57) **ABSTRACT**

Correspondence Address:

**Michael N. Spink
BRINKS HOFER GILSON & LIONE
P. O. Box 10395
Chicago, IL 60610 (US)**

A rear housing for a compressor reduces the operating temperature of the compressor. The compressor generally includes a cylinder block receiving low pressure fluid from the rear housing and providing high pressure fluid back to the rear housing. The rear housing defines a suction chamber and a discharge chamber. The rear housing further defines an isolation chamber positioned between the suction and discharge chambers. In this way, heat transfer between the higher temperature discharge fluid and the lower temperature suction fluid is reduced, thereby reducing the operating temperature of the compressor.

(73) **Assignee: Visteon Global Technologies, Inc.**

(21) **Appl. No.: 10/821,462**

(22) **Filed: Apr. 9, 2004**

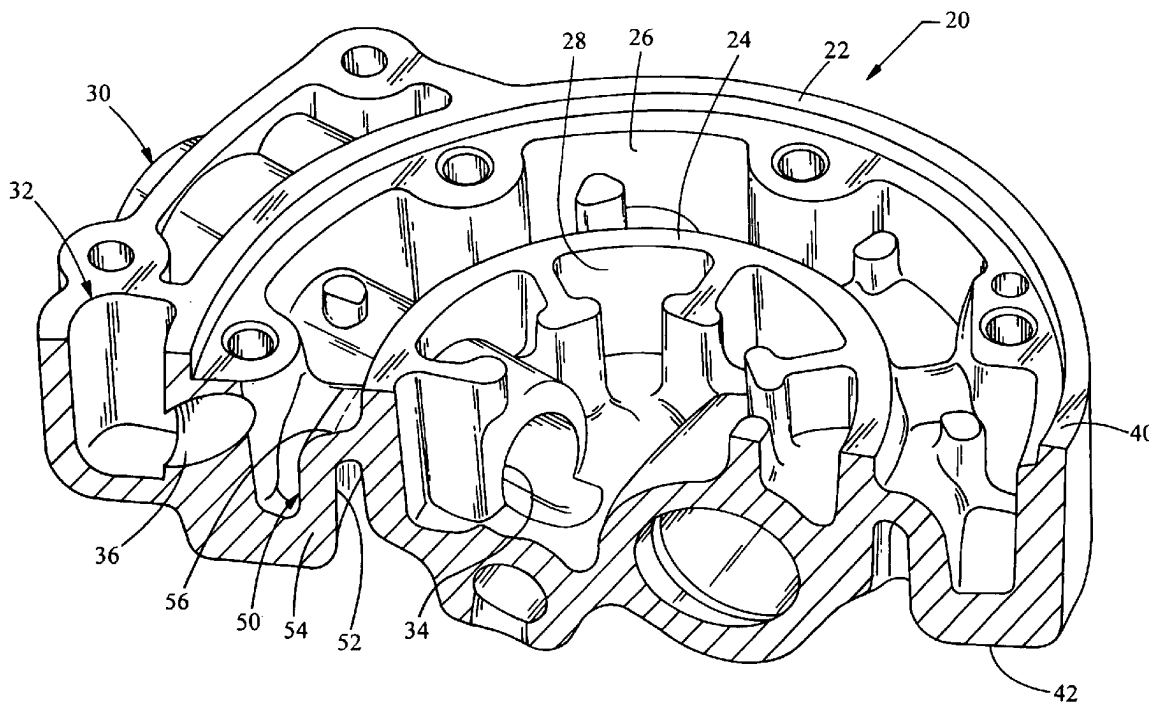

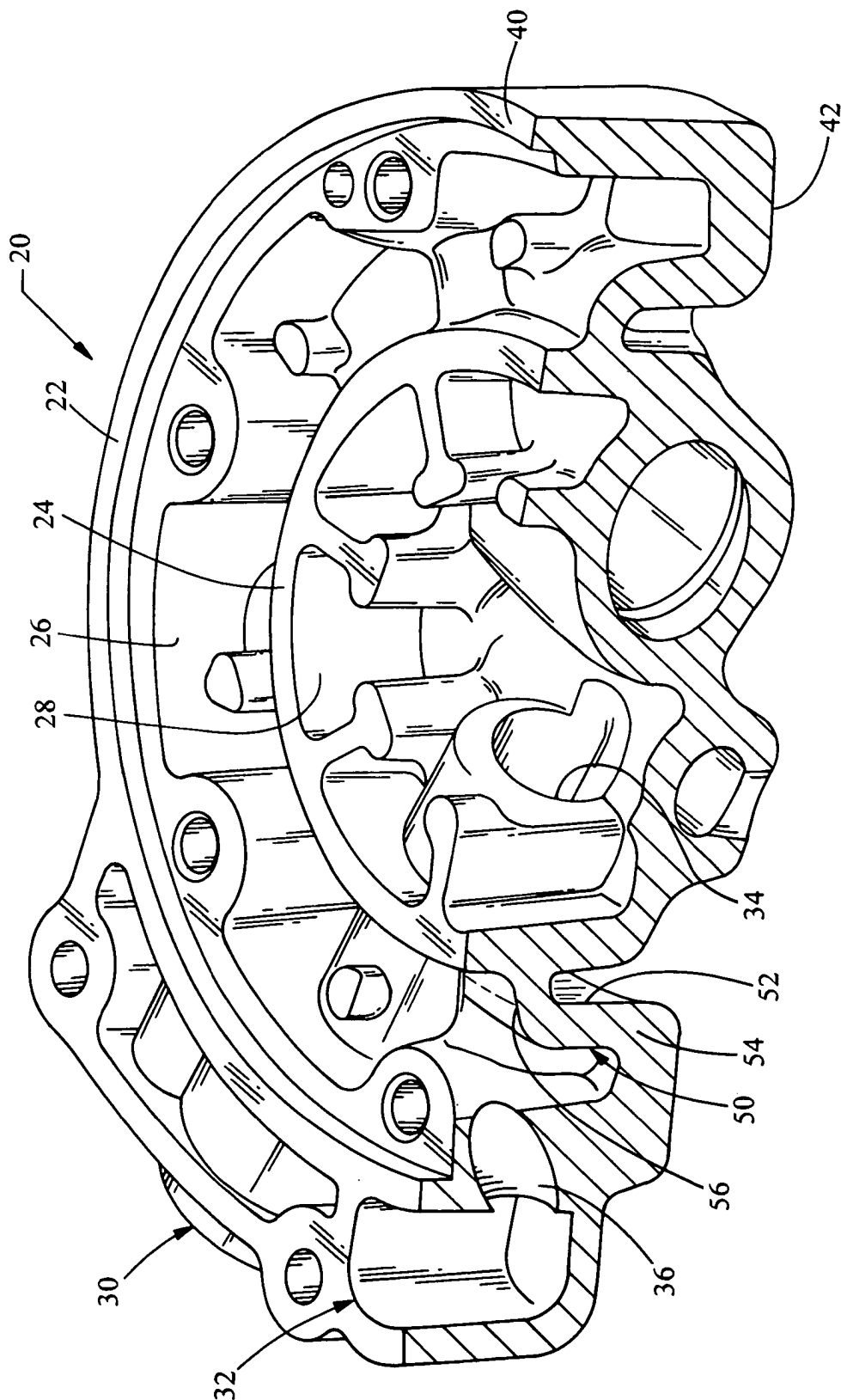

Fig. 1

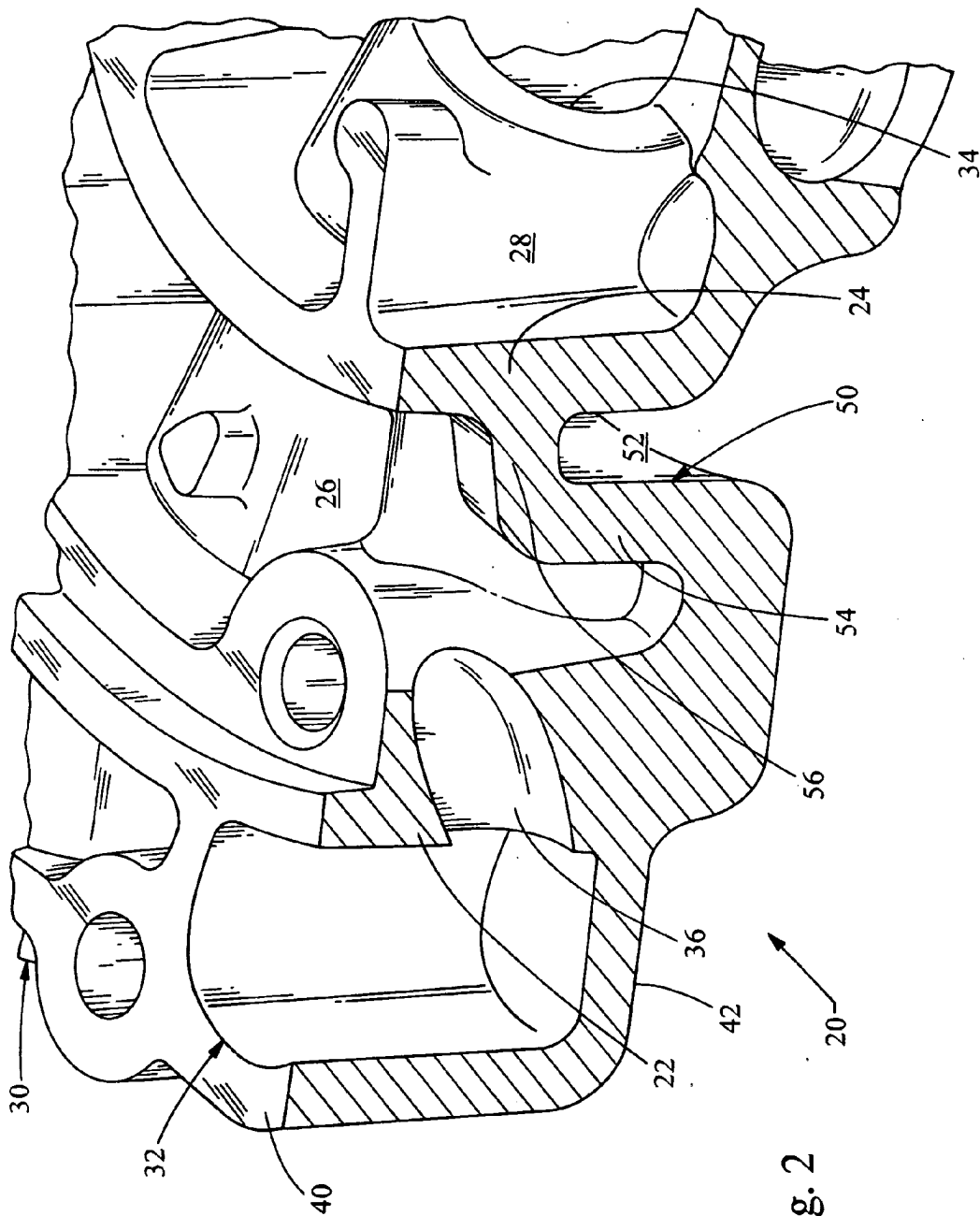

Fig. 2

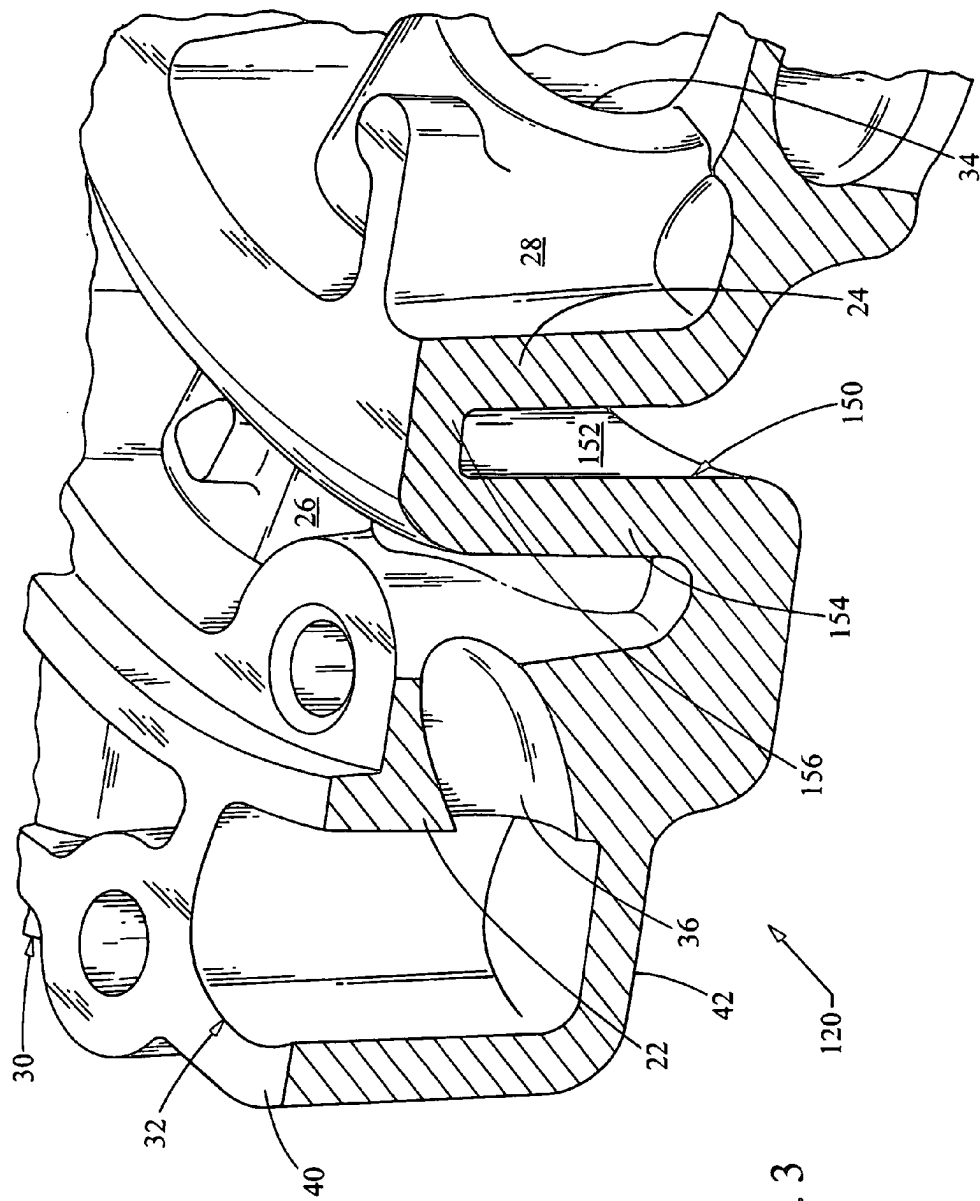

Fig. 3

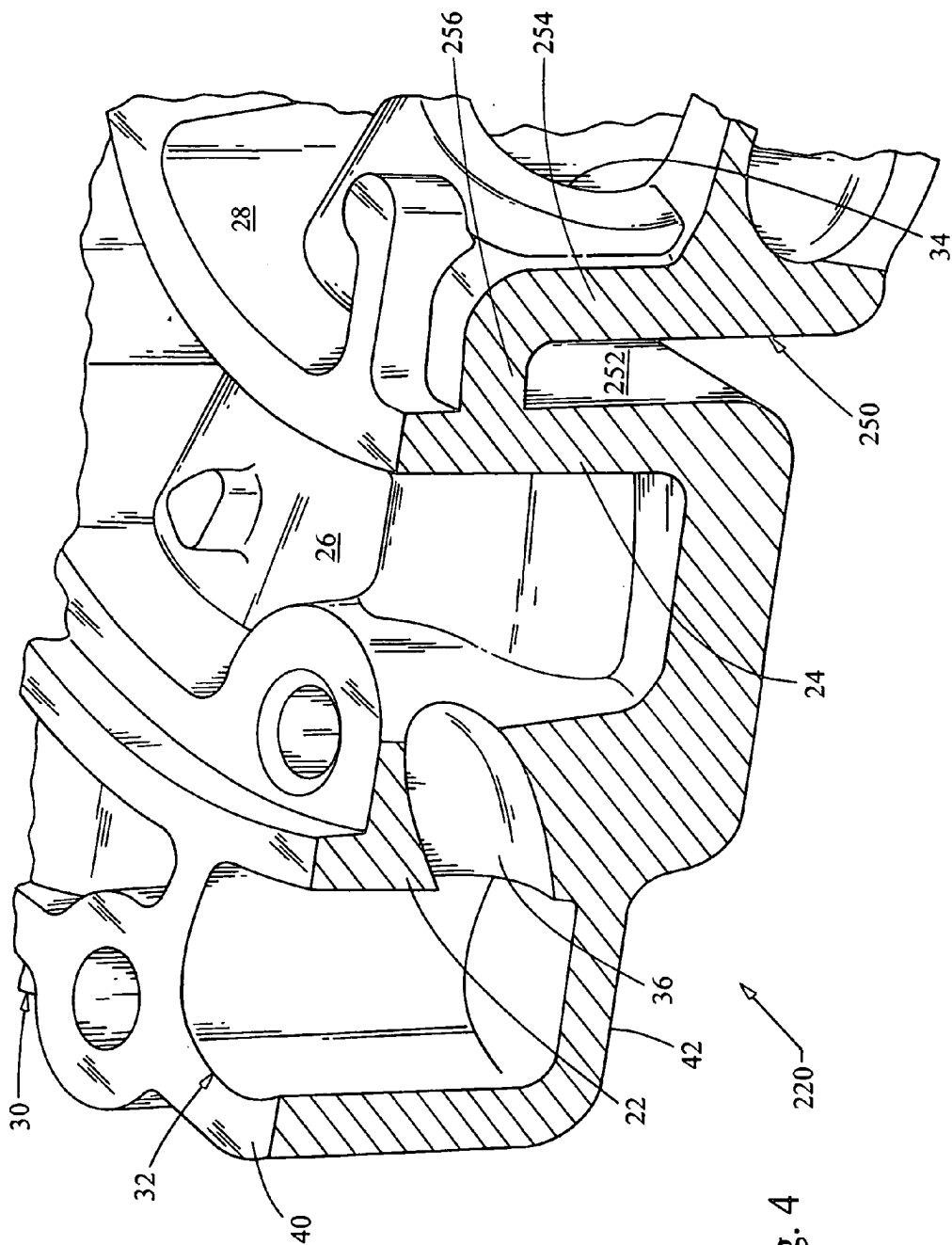

Fig. 4

COMPRESSOR HAVING REAR HOUSING STRUCTURE TO REDUCE THE OPERATING TEMPERATURE

FIELD OF THE INVENTION

[0001] The present invention relates generally to compressors, and more particularly relates to the structure of a rear housing of the compressor to reduce the operating temperature.

BACKGROUND OF THE INVENTION

[0002] Existing compressors, such as air conditioning compressors found in vehicles, contain an inherent problem of heat transfer. In normal use, a fluid such as a refrigerant gas enters the compressor via a suction chamber in the rear housing of the compressor. This suction fluid, under normal driving conditions, is around 80° F. The gas then proceeds through the cylinder block and its chambers where it is drawn into and exited by reciprocating piston movement, which compresses the fluid and discharges it out of the pump. Compressing a fluid within an enclosed volume increases its temperature usually by a factor of 2 to 3 times the original suction temperature. The final temperature of the discharge fluid is thus typically around 200° F. or higher. The discharge fluid exits the compressor via a discharge chamber also located in the rear housing and positioned adjacent the suction chamber. The suction and discharge chambers are typically separated by aluminum walls.

[0003] Unfortunately, the hot discharge fluid is in constant contact with the compressor's metallic walls, which generally offer very little thermal resistance, and allows the heat to increase the overall temperature of the compressor through contact conduction. Similarly, the temperature of the suction fluid in the suction chamber is also increased by the high temperature discharge fluid. In fact, the final temperature of the discharge fluid is directly proportional to the suction fluid temperature. Thus, there is a cyclic relationship between the suction and discharge fluids which generally increases the overall temperature of the compressor.

[0004] Elevated discharge fluid temperatures present a number of problems. First, a compressor's isentropic efficiency has an inverse relationship with discharge temperature, such that as the discharge temperature increases, the isentropic efficiency decreases, sometimes precipitously. As the isentropic efficiency drops, the necessary work input rises, which translates to requiring more engine horse power in an automotive air conditioning compressor. Likewise, the cooling capacity of the air conditioning system would also be decreased. Finally, elevated discharge temperatures reduce the durability of the compressor. Elevated operating temperatures can cause premature failure of the pistons, the swashplate, seals, bearings and other components of the compressor.

[0005] Accordingly, there exists a need to provide a compressor which reduces the operating temperature of the compressor to increase isentropic efficiency, cooling capacity and durability.

BRIEF SUMMARY OF THE INVENTION

[0006] The present invention provides a rear housing for a compressor that reduces the operating temperature of the

compressor. The compressor generally includes a cylinder block receiving low pressure fluid from the rear housing and providing high pressure fluid back to the rear housing. The rear housing generally comprises an annular outer wall and an annular inner wall circumscribed by the outer wall. A suction chamber is defined by the inner wall and provides low pressure fluid to the cylinder block. A discharge chamber is defined between the inner and outer walls, and receives high pressure fluid from the cylinder block. An annular isolation wall is structured to define an isolation chamber positioned between the suction and discharge chambers. In this way, heat transfer between the higher temperature discharge fluid and the lower temperature suction fluid is reduced, thereby providing a barrier to the cyclic relationship and reducing the temperature of the discharge fluid, which in turn reduces the operating temperature of the compressor.

[0007] According to more detailed aspects, the isolation wall may be disposed inside the inner wall, or alternatively may be disposed between the inner and outer walls. The isolation wall may include a first portion extending axially and a second portion extending radially and engaging the inner wall. The isolation chamber opens axially towards an end of the rear housing facing away from the cylinder block. The isolation chamber is preferably open to air, thereby providing a thermally insulating barrier.

[0008] The isolation chamber may completely separate the suction and discharge chambers, or may only partially separate the suction and discharge chambers. For example, the isolation wall may extend an axial distance that is less than an axial distance of the inner and outer walls. Likewise, the isolation chamber may extend axially a distance that is less than the maximum axial distance of the suction and discharge chambers. At the same time, the isolation chamber may extend only partially circumferentially around the inner chamber.

BRIEF DESCRIPTION OF THE DRAWINGS

[0009] The accompanying drawings incorporated in and forming a part of the specification illustrate several aspects of the present invention, and together with the description serve to explain the principles of the invention. In the drawings:

[0010] **FIG. 1** is a perspective view, partially cut away to reveal a cross section, of a rear housing for a compressor constructed in accordance with the teachings of the present invention;

[0011] **FIG. 2** is an enlarged view of a portion of **FIG. 1**;

[0012] **FIG. 3** is a perspective view similar to **FIG. 2**, but showing another embodiment of the present invention; and

[0013] **FIG. 4** is a perspective view similar to **FIGS. 2 and 3**, showing yet another embodiment of the present invention.

DETAILED DESCRIPTION OF THE INVENTION

[0014] Turning now to the figures, **FIGS. 1 and 2** depict perspective views, cut away to reveal a cross section, of a rear housing **20** forming a portion of a compressor (not shown). The rear housing **20** is structured for connection to

the cylinder block of the compressor, which includes a plurality of pistons reciprocating inside a plurality of cylinders to pressurize the working fluid, as is known in the art. The rear housing 20 is structured to provide a supply of low pressure fluid to the cylinder block and receive higher pressure fluid back from the cylinder block. The cylinder is preferably of a type suitable for use in an automobile, and in particular the air conditioning system of an automobile, and thus the working fluid preferably comprises a refrigerant gas.

[0015] The rear housing 20 generally includes an annular outer wall 22 and an annular inner wall 24 positioned inside and circumscribed by the outer wall 22. As used herein, "annular" refers to a ring-shape structure that may or may not have a particular beginning or end, although not necessarily circular. The space between the outer wall 22 and inner wall 24 defines a discharge chamber 26 that is annular in shape. The inner wall 24 defines a suction chamber 28 inside the periphery of the inner wall 24.

[0016] As previously noted, the suction chamber 28 is provided with a supply of working fluid via a suction port 30. The suction port 30 is connected to the suction chamber 28 via a suction passageway 34. Similarly, pressurized fluid from the block is received in the discharge chamber 26, which is fluidically connected to a discharge port 32 via a discharge passageway 36. The rear housing 20 generally includes a first axial end 40 and an opposing second axial end 42. The first axial end 40 generally exists in a single plane, and is structured to directly attach to the central housing and cylinder block of the compressor. The second end 42 of the rear housing 20 faces away from the cylinder block and generally has an undulating surface defining the rear end surface of the compressor.

[0017] The rear housing 20, and in particular the outer and inner walls 22, 24 are typically constructed of a metal such as aluminum, although other materials may be used. Aluminum is typically selected for its light weight properties, which is desirable under automotive requirements. Packaging requirements are also very limited in an automotive environment, and thus the discharge and suction chambers 26, 28 are located relatively close to one another. Accordingly, the present invention provides an isolation wall 50 which defines an isolation chamber 52 positioned between the discharge chamber 26 and suction chamber 28. As best seen in the enlarged view of FIG. 2, the isolation wall 50 generally includes a first portion 54 extending axially, and a second portion 56 extending radially. The second portion 56 extends into and engages the inner wall 24. The isolation chamber 52 is generally filled with air, as the second end 42 of the rear housing 20 is exposed. Air has relatively low thermal conductivity, and thus the isolation chamber 52 provides a thermal barrier between the high temperature fluid in the discharge chamber 26 and the lower temperature fluid in the suction chamber 28. It will be recognized by those skilled in the art that the isolation chamber 52 could be sealed off and provided with another medium such as a different fluid or gas which serves as thermal barrier, although the preferred construction is to leave the isolation chamber 52 open to the air for convective heat transfer.

[0018] Additional modifications of the isolation wall 50 and isolation chamber 52 will be readily envisioned by those skilled in the art, some of which have been depicted in

FIGS. 3 and 4. Common components between the embodiments have been referred to with common reference numerals in order to aid the understanding of the embodiments of FIGS. 3 and 4. With reference to FIG. 3, the isolation chamber 152 has been enlarged such that it extends axially from the second end 42 to the first end 40 of the rear housing 120. Thus, the isolation wall 154 extends axially a greater distance, although the first and second portions 154, 156 of the isolating wall 150 are generally of similar shape to the prior embodiment. In this way, the isolation chamber 152 completely separates the discharge chamber 26 from the suction chamber 28. This is different from the isolation chamber 52 in the prior embodiment which only partially separated the discharge chamber 26 from the suction chamber 28. It will also be recognized that the isolation chamber 52 of the prior embodiment only partially separated the chambers 26, 28 by virtue of extending only partially circumferentially around the suction chamber 28. That is, the isolation chamber 52 must accommodate such additional structures as the suction passageway 34 linking the suction chamber 28 to the suction port 30.

[0019] In FIG. 4, the rear housing 220 includes an isolation wall 250 and isolation chamber 252 positioned inside the inner wall 24. Referring back to the embodiments of FIGS. 1-3, the isolation wall 50, 150 and isolation chamber 52, 152 for position radially outside the inner wall 24 and between the inner and outer walls 24, 26. In this embodiment, the isolation wall 250 still includes a first portion 254 which extends axially and a second portion 256 which extends radially and engages the inner wall 24. While the isolation 250 and isolation chamber 252 are positioned inside the inner wall 24, the isolation chamber 252 still provides a thermal barrier between the discharge chamber 26 and suction chamber 28. As with all the prior embodiments, the isolation chamber 252 can be sized, both in terms of axial length and radial width, as well as filled with the proper medium, to provide sufficient thermal isolation between the discharge and suction chambers 26, 28 to reduce heat transfer.

[0020] Accordingly, it will be recognized that the present invention provides a rear housing structure that provides a thermal barrier between the discharge chamber containing higher temperature fluid, and a suction chamber containing lower temperature fluid. The thermal barrier is formed by an isolation wall and chamber which reduces the heat transfer between the chambers. In this way, the ability of the hot discharge fluid to heat up the cooler suction fluid is reduced, which in turn results in a reduction in the temperature of the discharge fluid in the discharge chamber. By breaking the aforementioned cycle, the overall operating temperature of the cylinder is reduced, resulting in greater isentropic efficiency, greater durability, an increased cooling capacity of an air conditioning system employing the compressor having the rear housing structure of the present invention.

[0021] The foregoing description of various embodiments of the invention has been presented for purposes of illustration and description. It is not intended to be exhaustive or to limit the invention to the precise embodiments disclosed. Numerous modifications or variations are possible in light of the above teachings. The embodiments discussed were chosen and described to provide the best illustration of the principles of the invention and its practical application to thereby enable one of ordinary skill in the art to utilize the

invention in various embodiments and with various modifications as are suited to the particular use contemplated. All such modifications and variations are within the scope of the invention as determined by the appended claims when interpreted in accordance with the breadth to which they are fairly, legally, and equitably entitled.

1. A rear housing for a compressor having a cylinder block receiving lower pressure fluid from the rear housing and providing higher pressure fluid back to the rear housing, the rear housing comprising:

- an annular outer wall;
- an annular inner wall circumscribed by the outer wall;
- a first chamber defined by the inner wall;
- a second chamber defined between the inner and outer walls; and
- an annular isolation wall, the isolation wall and inner wall defining an isolation chamber positioned between the first and second chambers.

2. The rear housing of claim 1, wherein the isolation wall is disposed between the inner and outer walls.

3. The rear housing of claim 1, wherein the isolation wall is disposed inside the inner wall.

4. The rear housing of claim 1, wherein the isolation wall includes a first portion extending axially and a second portion extending radially, the second portion of the isolation wall engaging the inner wall.

5. The rear housing of claim 1, wherein the rear housing includes a first end facing the cylinder block and a second end facing away from the cylinder block, and wherein the isolation chamber opens axially towards the second end.

6. The rear housing of claim 5, wherein the isolation chamber is open to air.

7. The rear housing of claim 1, wherein the isolation chamber completely separates the first and second chambers.

8. The rear housing of claim 1, wherein the isolation chamber partially separates the first and second chambers.

9. The rear housing of claim 8, wherein the inner and outer walls extend axially a first distance, and the isolation wall extends axially a second distance that is less than the first distance.

10. The rear housing of claim 8, wherein the first and second chambers extend axially a first distance, and the isolation chamber extends axially a second distance that is less than the first distance.

11. The rear housing of claim 8, wherein the isolation chamber extends partially circumferentially around the first chamber.

12. The rear housing of claim 1, wherein the first chamber is a suction chamber providing lower pressure fluid to the

cylinder block, and wherein the second chamber is a discharge chamber receiving higher pressure fluid from the cylinder block.

13. A rear housing for a compressor having a cylinder block receiving lower pressure fluid from the rear housing and providing higher pressure fluid back to the rear housing, the rear housing comprising:

- an annular outer wall;
- an annular inner wall circumscribed by the outer wall;
- a first chamber defined by the inner wall;
- a second chamber defined between the inner and outer walls;
- an annular isolation wall, the isolation wall and inner wall defining an isolation chamber positioned between the suction and discharge chambers; and

the rear housing including a first end facing the cylinder block and a second end facing away from the cylinder block, the isolation chamber opening axially towards the second end.

14. The rear housing of claim 13, wherein the isolation chamber is open to air.

15. The rear housing of claim 13, wherein the isolation wall is disposed between the inner and outer walls.

16. The rear housing of claim 13, wherein the isolation wall is disposed inside the inner wall.

17. The rear housing of claim 13, wherein the isolation wall includes a first portion extending axially and a second portion extending radially, the second portion of the isolation wall engaging the inner wall.

18. The rear housing of claim 13, wherein the isolation chamber completely separates the first and second chambers.

19. The rear housing of claim 13, wherein the isolation chamber partially separates the first and second chambers.

20. The rear housing of claim 19, wherein the suction and discharge chambers extend axially a first distance, and the isolation chamber extends axially a second distance that is less than the first distance.

21. The rear housing of claim 13, wherein the isolation chamber extends partially circumferentially around the suction chamber.

22. The rear housing of claim 13, wherein the first chamber is a suction chamber providing lower pressure fluid to the cylinder block, and wherein the second chamber is a discharge chamber receiving higher pressure fluid from the cylinder block.

* * * * *